

This drawing and this design and all novel and patentable features separately or collectively disclosed and included therein, are the property of Engineered Flexible Products, Inc., and are not to be copied or to be used directly or indirectly, by anyone whomsoever without the written consent of said company. This drawing is loaned subject to return to said company upon their demand.

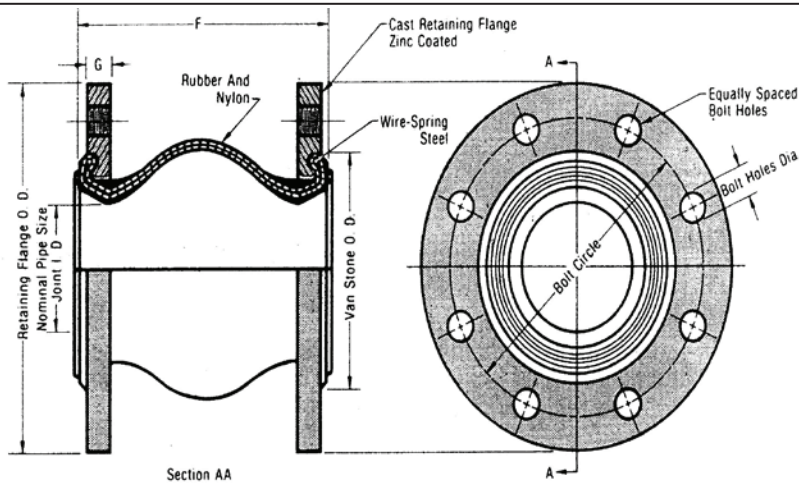

***Maximum Operating Conditions**

Temperature (°F)	Maximum Pressure PSI
	12" & Smaller
170°	225
180°	200
190°	175
210°	150
200°	125
220°	100
230°	75

Contact factory for other elastomers. Not for steam applications.

Data	Item Number	301EE0600	301EE0800	301EE1000	301EE1200	301EE1400
Number Required						
EFP Style Number		301EE0600	301EE0800	301EE1000	301EE1200	301EE1400
Dimensions	Pipe Size-Joint I.D.	6.00"	8.00"	10.00"	12.00"	14.00"
	F-Length of Joint	6.00"	6.00"	8.00"	8.00"	8.00"
	A-Flange Width	0.87"	0.87"	0.95"	0.95"	1.02"
Bolting	Flange/Ring O.D.	11.00"	13.50"	16.00"	19.00"	21.00"
	Bolt Circle	9.50"	11.75"	14.25"	17.00"	18.75"
	Number & Hole Size	8 - 0.88"	8 - 1.00"	12 - 1.00"	12 - 1.00"	12 - 1.13"
Movements	Axial Compression	0.750"	0.750"	1.000"	1.000"	1.000"
	Axial Extension	0.500"	0.500"	0.625"	0.625"	0.625"
	Lateral Deflection	0.500"	0.500"	0.750"	0.750"	0.750"
	Angular Movement	9°	7°	7°	6°	5°
Physical	Pressure Rating ⁽¹⁾	225 PSI	225 PSI	225 PSI	225 PSI	150 PSI
	Vacuum Rating ⁽¹⁾	26 In/Hg	26 In/Hg	26 In/Hg	26 In/Hg	26 In/Hg
	Temperature Rating	230 °F	230 °F	230 °F	230 °F	230 °F
	FSA Pressure Series	C	C	C	C	C
	FSA Material Class	Standard	Standard	Standard	Standard	Standard
Approx. Weights	Expansion Joint	26.8 LBS	40.6 LBS	56.6 LBS	83.0 LBS	101.0 LBS
	Control Unit Set(2 rods)	-	-	-	-	-
	Packing Crates	-	-	-	-	-
	Total Approx. Wght Ea.	26.8 LBS	40.6 LBS	56.6 LBS	83.0 LBS	101.0 LBS
Materials	Tube Elastomer	EPDM	EPDM	EPDM	EPDM	EPDM
	Cover Elastomer ^(®)	EPDM	EPDM	EPDM	EPDM	EPDM
	Body Fabric	NYLON	NYLON	NYLON	NYLON	NYLON
	Body Reinforcing	FABRIC	FABRIC	FABRIC	FABRIC	FABRIC
	Control Units	-	-	-	-	-

WARNING: Control units must be used to protect this part from excessive movement if piping is not properly anchored. Expansion joints may operate in pipelines or equipment carrying fluids and/or gases at elevated temperature and pressures. Normal precautions should be taken to make sure these parts are installed correctly and inspected regularly. Precautions should be taken to protect personnel in the event of leakage or splash.



5331 Quam Ave., N.E.
St. Michael, MN 55376 - USA
PH: 763-201-2151
FAX: 763-201-2134

SCALE: NONE

DWG NO: 9	PROP/INQ/ORD. NO:	REMARKS:
FORM NO: SINGLE SPHERE	CUSTOMER NAME:	⁽¹⁾ PRESSURE RATING IS BASED ON 170° F. MOVEMENTS ARE NON-CONCURRENT.
APPVD BY: RV CHECKED BY: RV	PROJECT NAME:	
PROD. DESC:	CONTRACTOR:	
PRINT CERTIFICATION: Certified correct as of 3/16/12 by R. Vance, (Pres.) Subscribed & sworn to before me, on this 16th day of March, 2012 By: _____ (Notary Public)	THE ABOVE EXPANSION JOINTS AND RELATED HARDWARE, MEET OR EXCEED THE PHYSICAL, MECHANICAL OR MATERIAL SPECIFICATIONS OF THE RUBBER EXPANSION JOINT DIV., FLUID SEALING ASSOCIATION. FOR ADDITIONAL INFORMATION, SEE THE ASSOCIATION, "TECHNICAL HANDBOOK, FIFTH EDITION", CHAPTER II, PARAGRAPH A.1. AND TABLES II, III, AND IV.	HAVE CONTROL UNITS BEEN SPECIFIED/ORDERED FOR THIS INSTALLATION: NO