

This drawing and this design and all novel and patentable features separately or collectively disclosed and included therein, are the property of Engineered Flexible Products, Inc., and are not to be copied or to be used directly or indirectly, by anyone whomsoever without the written consent of said company. This drawing is loaned subject to return to said company upon their demand.

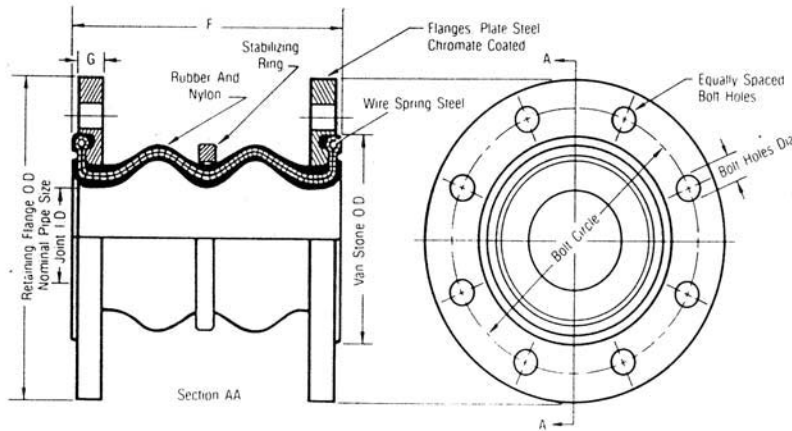

***Maximum Operating Conditions**

Temperature (°F)	Maximum Pressure PSI
	12" & Smaller
170°	UP TO 225
180°	UP TO 220
190°	UP TO 175
210°	UP TO 150
200°	UP TO 125
220°	UP TO 100
230°	UP TO 75

Contact factory for other elastomers. Not for steam applications.

WARNING: Control units must be used to protect this part from excessive movement if piping is not properly anchored. Expansion joints may operate in pipelines or equipment carrying fluids and/or gases at elevated temperature and pressures. Normal precautions should be taken to make sure these parts are installed correctly and inspected regularly. Precautions should be taken to protect personnel in the event of leakage or splash.

Data	Item Number	302EE0600	302EE0800	302EE1000	302EE1200	302EE1400
	Number Required					
	EFP Style Number	302EE0600	302EE0800	302EE1000	302EE1200	302EE1400
Dimensions	NOMINAL Pipe Size-Joint I.D	6.00"	8.00"	10.00"	12.00"	14.00"
	F-Length of Joint	9.00"	13.00"	13.00"	13.00"	13.75"
	G-Flange Width	0.87"	0.87"	0.95"	0.95"	1.02"
Bolting	Flange/Ring O.D.	11.00"	13.50"	16.00"	19.00"	21.00"
	Bolt Circle	9.50"	11.75"	14.25"	17.00"	18.75"
	Number & Hole Size	8 - 0.88"	8 - 1.00"	12 - 1.00"	12 - 1.00"	12 - 1.13"
Movements	Axial Compression	2.000"	2.375"	2.375"	2.375"	1.750"
	Axial Extension	1.375"	1.375"	1.375"	1.375"	1.118"
	Lateral Deflection	1.562"	1.375"	1.375"	1.375"	1.118"
	Angular Deflection	25°	19°	15°	13°	9°
Physical	Pressure Rating ⁽¹⁾	225 PSI	225 PSI	225 PSI	225 PSI	150 PSI
	Vacuum Rating ⁽¹⁾	26 In/Hg	26 In/Hg	26 In/Hg	26 In/Hg	26 In/Hg
	Temperature Rating	230 °F	230 °F	230 °F	230 °F	230 °F
	FSA Pressure Series	C	C	C	C	C
	FSA Material Class	Standard	Standard	Standard	Standard	Standard
Approx. Weights	Expansion Joint	29.5 LBS	43.8 LBS	65.5 LBS	95.0 LBS	115.0 LBS
	Control Unit Set	-	-	-	-	-
	Packing Crates	-	-	-	-	-
	Total Approx. Wght Ea.	29.5 LBS	43.8 LBS	65.5 LBS	95.0 LBS	115.0 LBS
Materials	Tube Elastomer	EPDM	EPDM	EPDM	EPDM	EPDM
	Cover Elastomer	EPDM	EPDM	EPDM	EPDM	EPDM
	Body Fabric	NYLON	NYLON	NYLON	NYLON	NYLON
	Body Reinforcing	FABRIC	FABRIC	FABRIC	FABRIC	FABRIC
	Control Units	-	-	-	-	-



5331 Quam Ave., N.E.
St. Michael, MN 55376- USA
PH: 763-201-2151
FAX: 763-201-2134

SCALE: NONE

PRINT CERTIFICATION: Certified correct as of 10/27/16 by R. Vance (Pres.) Subscribed & sworn to before me, on this 27th day of October, 2016

By: _____ (Notary Public)

DWG NO:	PROP/INQ/ORD. NO:	REMARKS:
FORM NO: TWIN SPHERE	CUSTOMER NAME:	(1) PRESSURE RATING IS BASED ON 170° F. MOVEMENTS ARE NON-CONCURRENT.
APPVD BY: RV CHECKED BY: RV PROD. DESC:	PROJECT NAME: CONTRACTOR:	SEE ATTACHED FOR CONTROL ROD REQUIREMENTS
THE ABOVE EXPANSION JOINTS AND RELATED HARDWARE, MEET OR EXCEED THE PHYSICAL, MECHANICAL OR MATERIAL SPECIFICATIONS OF THE RUBBER EXPANSION JOINT DIV., FLUID SEALING ASSOCIATION. FOR ADDITIONAL INFORMATION, SEE THE ASSOCIATION, "TECHNICAL HANDBOOK, FIFTH EDITION", CHAPTER II, PARAGRAPH A.1. AND TABLES II, III, IV.		HAVE CONTROL UNITS BEEN SPECIFIED/ORDERED FOR THIS INSTALLATION: NO

Table 6: Control Units/Unanchored

Control Units must be installed when pressures (test • design • surge • operating) exceed rating below:

Pipe Size	Series 301 P.S.I.G.	Series 302 P.S.I.G.
1" thru 4"	180	135
5" thru 10"	135	135
12" thru 14"	90	90
16" thru 24"	45	45
30"	35	35

Table 7:		Maximum Surge or Test Pressure of the System			
Nominal Pipe Size Expansion Joint I.D. Inch /(mm)		Number of Control Rods Recommended			
		2	4	6	8
1	(25)	949	•	•	•
1.25	(32)	830	•	•	•
1.5	(40)	510	•	•	•
2	(50)	661	•	•	•
2.5	(65)	529	•	•	•
3	(75)	441	•	•	•
4	(100)	311	622	•	•
5	(125)	235	470	•	•
6	(150)	186	371	•	•
8	(200)	163	326	•	•
10	(250)	163	325	488	•
12	(300)	160	320	481	•
14	(350)	112	223	335	•
16	(400)	113	227	340	453
18	(450)	94	187	281	375
20	(500)	79	158	236	315
24	(600)	74	147	221	294
30	(750)	70	141	211	281

Note:

Pressures listed above do not relate to the actual design pressure of the expansion joint products, but are the maximum surge or pressure for a specific control rod nominal pipe size.